

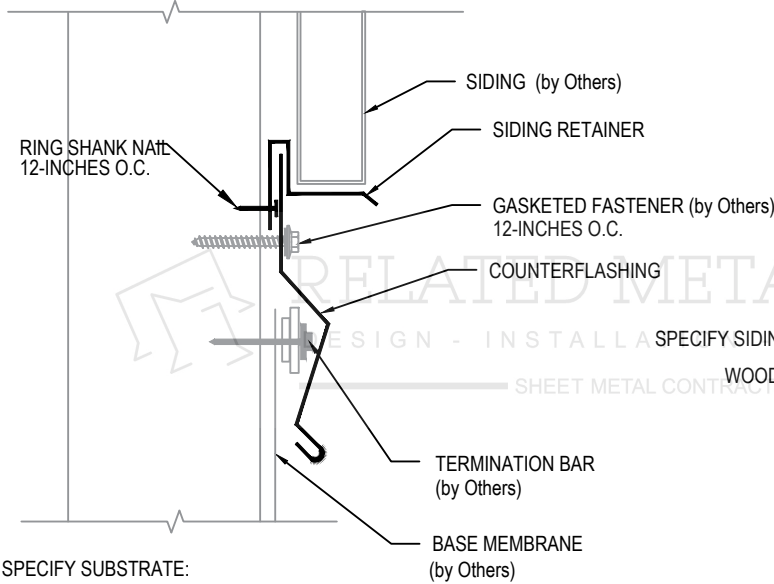

**Counterflashing
 2 Piece Siding Retainer
 RM-CF11**

Product Submittal / Order Form



SPECIFY SUBSTRATE:
 WOOD MASONRY

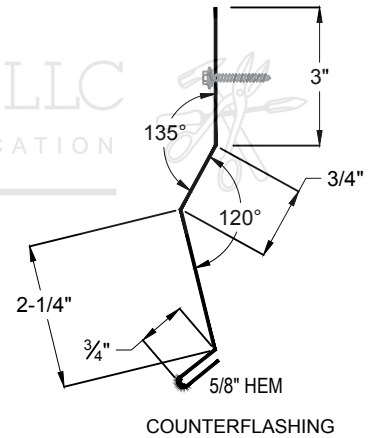
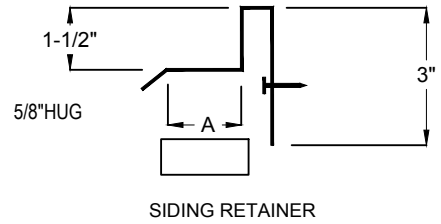

QUANTITY

_____ Total Lineal Feet

THICKNESS / MATERIAL

- 0.032 Aluminum
- 0.040 Aluminum
- 0.050 Aluminum
- 0.063 Aluminum
- 24 ga. Galvanized Steel
- 22 ga. Galvanized Steel
- 24 ga. Stainless Steel
- _____

FINISH

- Mill Finish
- Kynar 500
- Hyperlon 500
- Polished

COLOR

PROJECT

CUSTOMER: _____
JOB NAME: _____ **JOB # :** _____
LOCATION: _____
DISTRIBUTOR: _____

CUSTOMER APPROVAL

Date: _____

- Approved for Fabrication
- Approved with Changes
- Not Approved / Resubmit

Signature: _____

Printed Name: _____

COMPLIANCE Contact Related Metals for verification of test report data for your project.

